

Installation and User Manual

Maritime TVRO systems

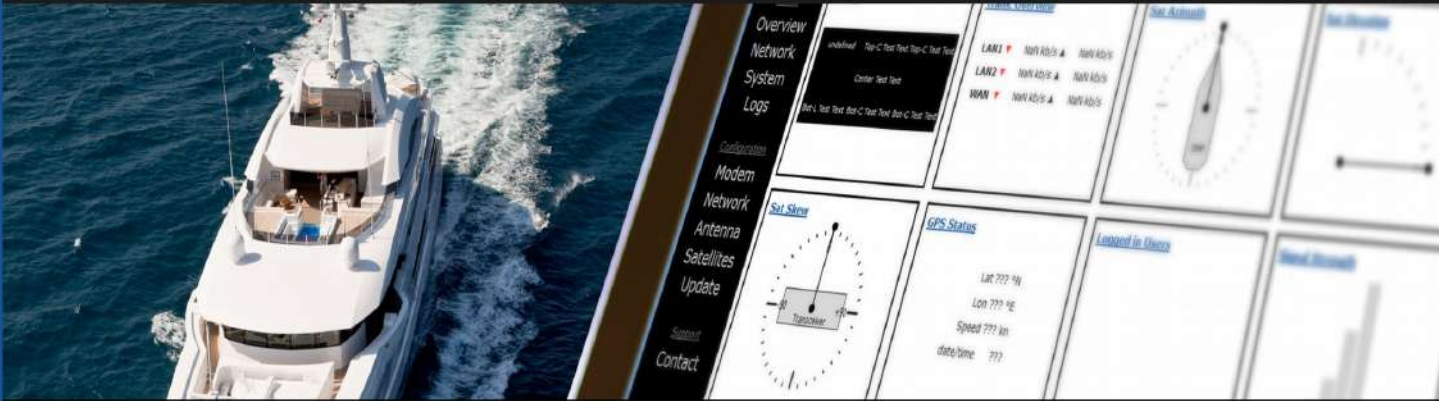

DS6 PRO
DS9 PRO
DS13 PRO



EPAK Support Contact Details

Please contact us for any technical enquiries:

EPAK GmbH
Spinnereistr. 7
04179 Leipzig
Telephone Business hours +49 (0) 341 – 2120260
Emergency Telephone (active during weekends and holidays, 9h-18h): +49 (0) 1575-7954223
Email: support@epak.de

Please keep your serial number ready.

TVRO Serial Number



Figure 1: Antenna label with serial number

The serial number (standard format: 090UC.10.1843.0000) will be required for all service requests regarding this product.

You can find the serial number of your EPAK TVRO system both engraved on the chassis of the antenna (Figure 1) and on the delivery note sent to you with the system.

Disclaimer

Any responsibility or liability for loss or damage in connection with the use of this product and the accompanying documentation is disclaimed by EPAK. The information in this manual is provided for information purposes only, is subject to change without notice and may contain errors or inaccuracies. Manuals issued by EPAK are periodically revised and updated. Anyone relying on this information should acquire the most current version e.g. from <https://www.epak.de>. EPAK is not responsible for the content or accuracy of any translations or reproductions, in whole or in part, of this manual from any other source.

Copyright

© 2021 EPAK GmbH. All rights reserved.

Trademark acknowledgements

EPAK is a registered trademark of EPAK GmbH.

Contents

| | | |
|----------|---|-----------|
| 1 | Introduction | 4 |
| 2 | Safety Recommendations & Precautions | 5 |
| 2.1 | Radar interference | 5 |
| 2.2 | Exposure to rain / moisture | 5 |
| 2.3 | Necessity of grounding the equipment | 5 |
| 2.4 | Power supply | 5 |
| 2.5 | Maintain ambient temperature for IDU | 5 |
| 2.6 | Maintain ambient temperature for ODU | 5 |
| 3 | System Components List | 6 |
| 4 | Installation Procedure | 8 |
| 4.1 | Tools Required for Installation | 8 |
| 4.2 | Select Antenna location | 8 |
| 4.2.1 | Free line-of-sight toward satellite | 8 |
| 4.2.2 | Radar interferences | 9 |
| 4.3 | Planning the cable paths | 9 |
| 4.4 | Drilling | 10 |
| 4.5 | Installing the Antenna | 12 |
| 4.6 | Installation on a mast | 12 |
| 4.7 | Removing the Transport Lock of the Antenna | 13 |
| 4.8 | Installing the Indoor Unit | 14 |
| 4.9 | Power supply for TVRO system | 15 |
| 4.10 | Antenna Grounding | 15 |
| 4.11 | System Cable Connections | 16 |
| 4.12 | Wiring TVRO Ku-Band Systems | 18 |
| 5 | Operating the TVRO system | 19 |
| 5.1 | ACU panel | 19 |
| 5.2 | Accessing the ACU | 22 |
| 5.2.1 | Status -> Dashboard | 23 |
| 5.2.2 | Status -> Network | 24 |
| 5.2.3 | Status -> System | 24 |
| 5.3 | System Configuration | 25 |
| 5.3.1 | Configuration -> Priority | 26 |
| 5.3.2 | Configuration -> Antenna | 28 |
| 5.3.3 | Configuration -> Satellite | 28 |
| 5.3.4 | Configuration -> Versions -> Update Section | 28 |
| 5.4 | Account Details | 30 |
| 5.5 | Maintenance | 30 |
| 5.6 | Individual dome painting | 31 |
| 6 | Hardware configuration | 31 |
| 6.1 | LNBS | 31 |
| 6.2 | NMEA Connector | 31 |
| 7 | Datasheets | 32 |
| 7.1 | Antenna | 32 |
| 8 | Glossary | 33 |

1 Introduction

Intended readers

This is an installation and user manual for the EPAK TVRO systems PRO Series, intended for installers of the system and service personnel. Personnel installing or servicing the system must be properly trained and authorized by EPAK. It is important that you observe all safety requirements listed in the beginning of this manual, and install the system according to the guidelines in this manual.

Product Description

EPAK TVRO antennas are automatic satellite tracking systems for TV reception made for maritime applications. EPAK's TVRO systems are designed to track satellites providing TV services with great precision in real-time response to the ship's motions even in rough sea conditions.

Such TVRO systems consist of two major units, the antenna Outdoor Unit (ODU) and the Indoor Unit (IDU). The ODU is protected by a UV-stabilized, maritime climate-proof, and easy-to-maintain radome. The antenna uses a 3-axis motion system, with automatic skew adjustment. This feature in combination with state-of-the art tracking technology (twin RF tracking receiver + 6D inertial + GNSS & NMEA - optional) guarantees an unmatched tracking speed up to 50%. The IDU consists of the Antenna Control Unit (ACU) and the Uninterrupted Power Supply (UPS).

This unit provides an easy-to-use web interface for configuring the antenna, checking the antenna's current status and configuring your network.

To guarantee the highest performance and reliability, EPAK designs and engineers all of its antennas' major RF components, control boards, mechanical parts and radome in house. All the components are optimized for rough marine applications. From small vessels up to super yachts, no matter whether sailing or motor yachts, EPAK TVRO series are eminently suitable for all types of vessels.

Once the connection to a satellite is established, the system will stay connected due to a 360° high-speed tracking system. That guarantees a non-stop reception of your favourite television channels while the vessel is anchored or even while cruising in open seas with rough conditions. The antennas are available in dish sizes in the range of 60 cm, 90 cm and 130 cm (DS6, DS9 and DS13 respectively).

EPAK also offers several additional options to accommodate special requirements. The Diversity Kit assures the avoidance of blind spots by combining the free line of sight ranges of two antennas in one bundle. This will prevent any loss of satellite signal through blockages. Additionally, EPAK also offers a vessel management router for network control, WiFi services, and Voip/Voice connections.

Your safety

All personnel who operate equipment or do maintenance as specified in this manual must know and follow the safety precautions. The warnings and cautions that follow apply to all parts of this manual.

2 Safety Recommendations & Precautions

2.1 Radar interference

- The antenna must be mounted as far away as possible from the ship's radar and high-power radio transmitters as they can affect the antenna performance. To avoid the worst interference, the antenna should be mounted at a different vertical level - either 15° above or 15° below the radar. Kindly note the recommended minimum distances between the ODU and X-band/S-Band radars in Table 4.2.3.
- After the installation is completed all other electronic systems, i.e. GPS, Radar, VHF, FM, AM etc., should be tested for full functionality while the antenna is switched on.

2.2 Exposure to rain / moisture

- Do not open sealed electronic components on the ODU and the ACU. Doing that will void the warranty of the equipment.
- The ACU and the UPS must always be kept indoors. Exposure to rain, sunlight, or moisture may damage the equipment.

2.3 Necessity of grounding the equipment

Grounding of the equipment is necessary to avoid potential differences between the ship's ground potential and the equipment's. The antenna's ground connection shall be connected directly to the ship's ground to avoid undesired current flow. For details refer to paragraph 4.9 Grounding.

2.4 Power supply

The ACU requires 90-264V AC @ 47-63 Hz Input voltage & frequency. The ACU then supplies DC power to the Antenna. Use of an online UPS is mandatory for EPAK systems, otherwise, the warranty becomes void. For more details see 4.8.

2.5 Maintain ambient temperature for IDU





Proper cooling and ventilation are required for all indoor equipment. The ACU can be stored at a temperature between -40°C to 85°C . During operation, the ambient temperature must be maintained between -20°C to 55°C . Frequent imbalances in the environment can damage the IDU electronics.

2.6 Maintain ambient temperature for ODU

Operating temperature for the ODU ranges from -20°C to 55°C , while the storage temperature range is between -30°C to 85°C . When temperatures fall below -30°C , the antenna system must be kept on to avoid damage to electronic parts at re-start. Alternatively an antenna heating system should be used.

3 System Components List

In our standard delivery, you will find the following system components.

| Component | Details |
|---|--|
| <p>ODU</p>  | <p>Description</p> <ul style="list-style-type: none"> • Stabilized Antenna Pedestal with electronic control modules • Feed-assembly • Ku band LNB • Inbuilt GPS receiver • Radome assembly <p>Features</p> <ul style="list-style-type: none"> • 3-axis motion system + auto skew adjustment • Range movement from -15° to $+120^{\circ}$ • Tracking speed up to 50%/s |
| <p>ACU (IDU)</p>  | <p>Description</p> <ul style="list-style-type: none"> • Antenna Control Unit • Power cable and Ethernet cable <p>Functionality</p> <ul style="list-style-type: none"> • Configuring satellite & beams • Monitoring live status of the antenna • Providing Internet access & voip services to the vessel |
| <p>Mounting screws</p>  | <p>DS6 / DS9 4 mounting screws DS13: 12 mounting screws</p> |
| <p>TVRO manual</p>  | <p>TVRO manual for easy operation & configuration of the system. Up-to-date documents are available for download on www.epak.de/en.</p> |

Add-ons (Optionally supplied by EPAK)

| Component | Description |
|---------------------|---|
| LTE Antenna | 3G/4G Outdoor Antenna for low-cost coastal internet |
| UPS | Online UPS system (mandatory) |
| Cables | Antenna to ACU ACU to LTE For details see 4.11 Wiring |
| Multi-Switch | Connects up to 6 /8 /12 /16 receiver |
| Lifting Tool | For lifting the antenna during installation / de-installation |
| Fibre Link | Plug-in system that enables signal transmission via fibre optic cables instead of coax cables |

4 Installation Procedure

The installation of our systems is easy compared to existing TVRO systems. This section gives a guideline and answers all your questions on how and where to install the ODU and IDU. It is highly recommended to plan your installation according to this in order to prevent mistakes and damages to the vessel or the TVRO system.

4.1 Tools Required for Installation

The following tools are required for installation.

| | | | |
|--|---|---|---|
|  <p>electric drill; screwdriver</p> |  <p>4 mm and 8.5-9 mm drills</p> |  <p>Hexagon socket screw key size 6</p> |  <p>size 13 screw wrench</p> |
|--|---|---|---|

4.2 Select Antenna location

The antenna's selected mounting position should have the following characteristics.

4.2.1 Free line-of-sight toward satellite

The antenna needs a free line of sight to the satellite for uninterrupted operation. Any obstacles can reduce service availability and tracking performance. Please note that the free line of sight depends on the vessel's geolocation and the selected satellite. The best location for the antenna is on a raised platform or on one end of the vessel as shown in Figure below.



Bad location: in such a situation it is very likely to incur a wide blind spot.

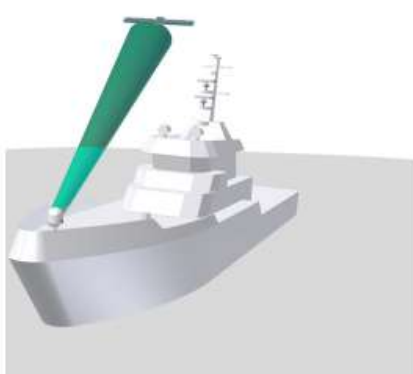

Better: by setting the antenna to one end of the ship, the obstacle can be overcome.



Best location: if possible, place the antenna on top of the boat.

Figure 4.1: Finding the best location for the antenna

4.2.2 Radar interferences

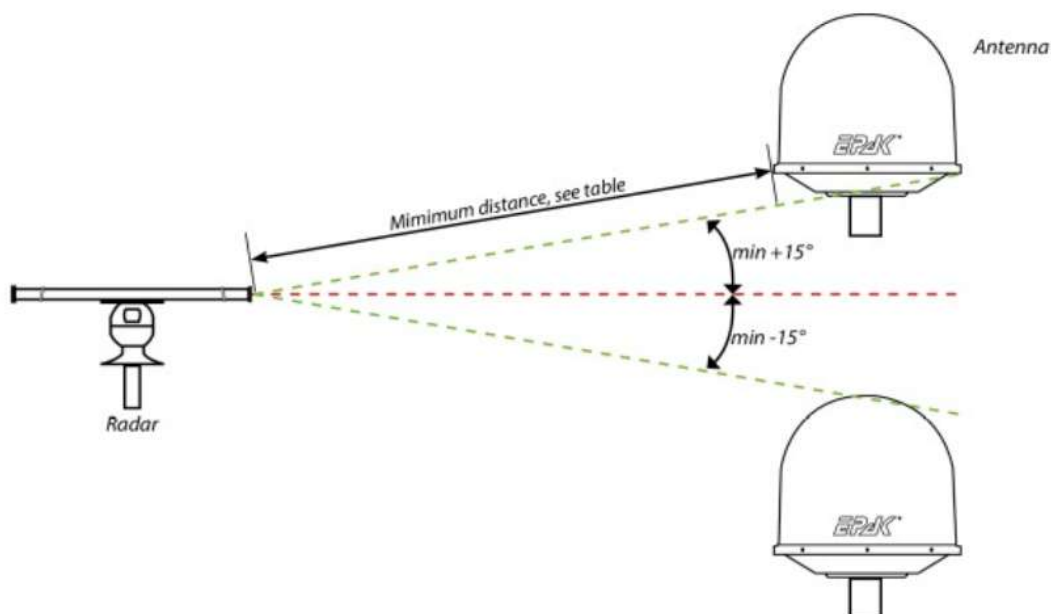

Figure 4.2: Minimum safe distance from the radar

It is very important to not install the antenna near the radar. Radars and satellite antennae operate in the microwave region of the electromagnetic spectrum. A radar placed close to the ODU can degrade the antenna's performance. Thus it is necessary to maintain the minimum distance between the two pieces of equipment.

The minimum acceptable separation between a radar and the antenna is determined by the radar wavelength/ frequency and the power emitted by the radar. The table below shows some "rule of thumb" minimum separation distances for radar power at X- and S band. As long as the minimum distance listed below is applied, antenna damage is normally avoided.

| | X- Band (~3 cm/ 10 GHz) min distance | S- Band (~3 cm/ 10 GHz) min distance |
|-------------|--|--|
| Radar Power | Minimum distance between TVRO and Radar with 20° vertical separation | |
| 0-20 kW | 1.0 m | 2.0 m |
| 20-50 kW | 2.0 m | 4.0 m |
| 50 kW+ | 3.5 m | 7.0 m |

The presence of one or more S- or X-band radars within a radius up to 100 m may cause a minor degradation of the Ku-band connection. The degradation will be most significant at high radar pulse repetition rates. Especially in poor receiving conditions (objects blocking the signal path, heavy rainfall or icing, low satellite elevation and violent ship movements) the small extra degradation due to the radar(s) could cause poor connection quality.

4.3 Planning the cable paths

Please check which walls are suitable and if existing openings can be used for the cables. Laying the cables is usually done by an electrician in the dockyard with proper certificates to alter the ships installations or the ships structure. If you're in charge of laying the cables, make sure it is done in accordance with the following rules:

- Use suitable coax cables: Double shielded RG6/RG11 with solid copper core is recommended for the connection between ACU and the antenna. EPAK warranty does not cover decreased performance due to improper wiring.
- The maximum recommended cable length for RG6/RG11 is 50 m. Make sure that the cable length does not exceed this value. If maximum cable length is too short for your installation, favour higher grade cables over in-line amplifier.
- Avoid placing RF cables too close to other cables which might carry "noise".
- Fit and secure cables properly. Use shrink tubing with heat-activated adhesive to seal connectors. - Avoid sharp bends and kinks on cables.
- To connect the antenna and ACU, use cables in one piece; do not extend cables, and do not split cables.
- Use only high-quality RF connectors.

4.4 Drilling

For an ideal mounting of the antenna, all possible drilling patterns are prepared with a pre-drilled hole of 2 mm in the bottom of the radome. Please refer to the included templates for the drilling measurements. Installation should be done with the supplied M10x35 screws. They can be used for a mounting plate thickness of up to 15 mm. For thicker plates from 15 mm to 30 mm use M10 × 50 screws.

Note: Using longer screws than recommended could potentially cause damage to the system.

Dimensions and drilling patterns

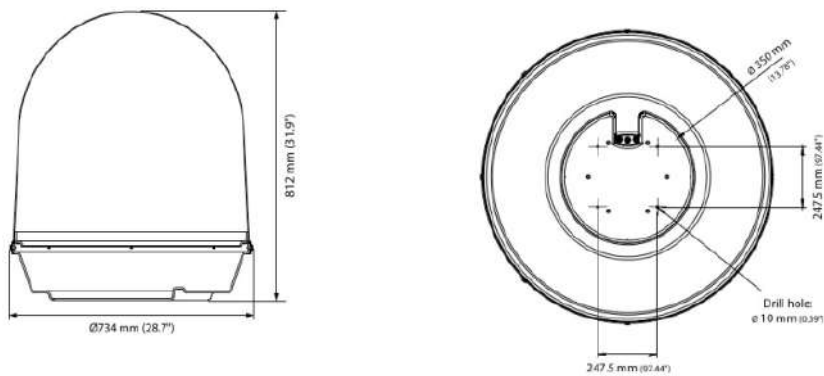

[Click for full view or refer to page 34](#)

Figure 4.3: Dimensions 60 cm antenna dome (front and bottom)

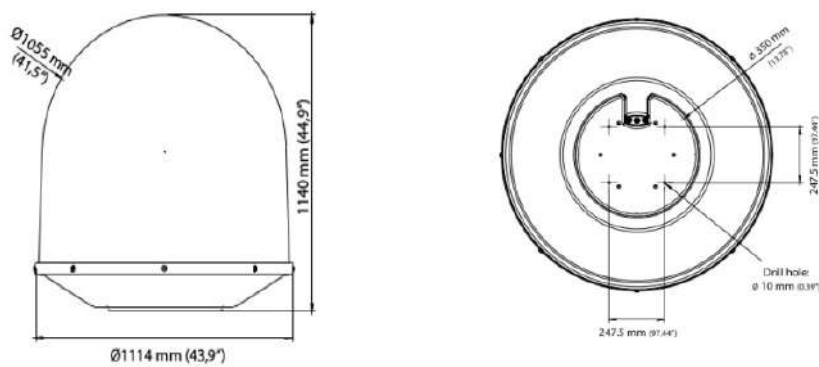

[Click for full view or refer to page 35](#)

Figure 4.4: Dimensions 90 cm antenna dome (front and bottom)

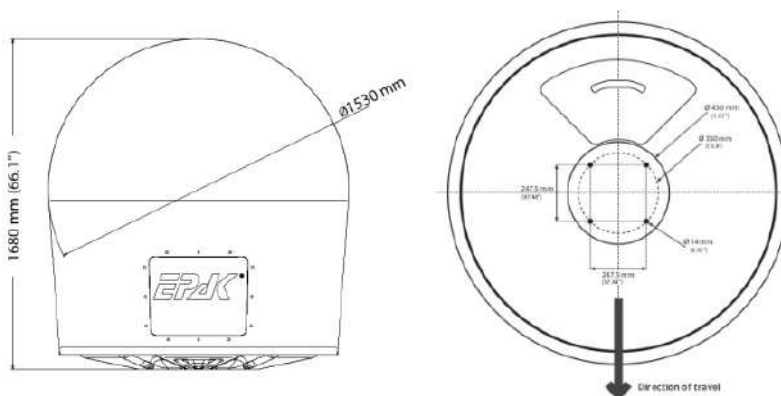

[Click for full view or refer to page 36](#)

Figure 4.5: Dimensions 130 cm antenna dome (front and bottom)

4.5 Installing the Antenna

Before installing the antenna, please take the following precautions:

⚠ Caution:

- The radome has to be properly fixed on the antenna before installing it on the platform.
- For safety during transport, the antenna has locks for the movement in skew, elevation, roll, and azimuth. **Do not open these transportation locks before installation.**

Procedure:

- Ensure that the mounting base is solid and steady.
- The antenna unit must have a clear line of sight to the satellite and there should be no interference.
- Make sure that the cable lengths are sufficient to reach the mounting platform.
- Prepare the mast / mounting pedestal with the drilling measurements shown in section 4.3.
- Now, attach a 4-part sling around the antenna to lift and place the unit on the pre-drilled holes and fasten it with the included screws. The screws have to be mounted from below and through the base plate of the antenna.
- Connect the 5 coaxial cables at the base of the antenna.
- Close all drilled holes with waterproof sealing material to avoid any water penetration.
- Finally, open all the transportation locks according to our manual before operating the antenna.

4.6 Installation on a mast

The below table shows the minimum dimensions for the mast when mounting an EPAK DSi9 VSAT. Note that the values are only guidelines. Always consider the environment and characteristics of the ship before deciding on the mast dimensions.



Mast without braces

| Max. free mast length (steel, m) | Outer diameter (mm) | Wall Thickness (mm) | Weight (kg/m) |
|----------------------------------|---------------------|---------------------|---------------|
| 0.6 | 220 | 5 | 26.5 |
| 0.8 | 250 | 5 | 30.2 |
| 1.0 | 270 | 5 | 32.7 |

Mast with 3 braces



| Max. free mast length (steel, m) | Outer diameter Mast (mm) | Wall Thickness Mast (mm) | Outer Diameter Braces (mm) with 5mm thickness |
|----------------------------------|--------------------------|--------------------------|---|
| 1.2 | 140 | 10 | 50 |
| 1.2 | 200 | 5 | 50 |
| 1.6 | 140 | 10 | 70 |
| 1.6 | 200 | 5 | 70 |
| 2.0 | 160 | 10 | 70 |
| 2.0 | 200 | 5 | 70 |
| 2.5 | 180 | 10 | 80 |
| 2.5 | 220 | 5 | 80 |
| 3.5 ¹ | 245 | 6 | 80 |

4.7 Removing the Transport Lock of the Antenna

After the system has been securely placed on the mounting platform, only then proceed to remove the transportation lock. It is important to note that the transportation lock must be removed before powering on the system otherwise, this will impose strain on the mechanics of the antenna.

Four handles are used to lock the skew, elevation, roll, and azimuth movement of the antenna. A visible red dot on the handle indicates that the handle is locked. A green dot indicates that it is open. To open or close, pull the handle towards you and turn until it locks in the new position. Confirm by checking the movement of the antenna.



Figure 4.6: Position of transport locks

¹Braces meet at 2.5m and mast extends beyond



Step 1 Release the **skew** movement by turning the handle into an upward position as shown in the figure.



Step 2 Release the **elevation** movement by turning the handle to a downward position as shown below.



Step 3 Release the **roll** movement by turning the handle to the right as shown in the figure below.



Step 4 Release **azimuth** movement by turning the handle left as shown below.

Figure 4.7: Transportation lock open-closed

4.8 Installing the Indoor Unit

Before installing the IDU, find a suitable location for the equipment within cable lengths. Ensure that the display of the control unit can be easily read and the front-panel is accessible. Also, allow sufficient room for connecting the cables behind the control unit. Check the following diagram to find the dimensions of the unit.



Figure 4.8: ACU Front view

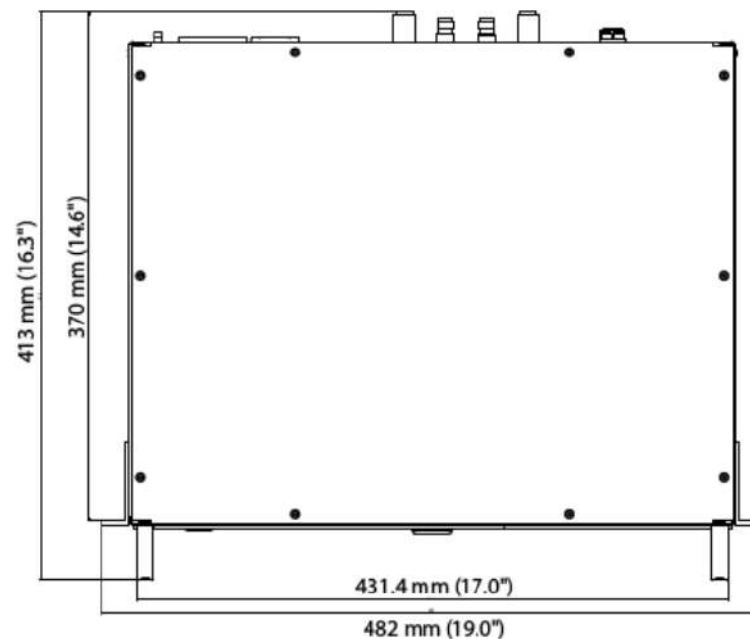

Figure 4.9: ACU Top view

The following points need to be considered during the installation of the IDU

- All IDU components (ACU+UPS) should be mounted in a professional 19" server rack. For the installation, operation, and maintenance enough space should be available at the front and also some space must be allowed behind the unit for the cables.
- Proper cooling and ventilation are required for all IDUs. The ACU should be stored within a temperature range of -40°C to 85°C . During operation, the ambient temperature must be maintained between -20°C to 55°C .
- Fresh air intake is from the front of the ACU, and warm air is dispensed out the back. Therefore, Both front and back panels of the ACU must be kept clear to allow ventilation. Otherwise, overheating might cause system shutdown.
- Either the UPS is provided by EPAK or a compatible UPS (on-line/double-conversion type) has to be installed by the ship owner for powering the IDU.

4.9 Power supply for TVRO system

The ACU requires 90 – 264 V AC @ 47 – 63 Hz, 1 phase. However, as the power supplied by vessel generators can fluctuate considerably, an online-type UPS is compulsory for the EPAK TVRO system otherwise the warranty becomes void. The ACU supplies the ODU with 42 V DC power.

⚠ Caution: Grounding of the equipment is necessary to avoid potential differences between the ship's ground potential and the equipment's. The antenna's ground connection can be connected directly to the ship's ground to avoid undesired current flow.

4.10 Antenna Grounding

When grounding the antennas, there are two different scenarios.

Case 1: The potential of the antenna corresponds to that of the platform/mast/hull

Case 2: The potential of the antenna does not correspond to that of the platform/mast/hull

Case 1 is the standard scenario for all 60 cm and 90 cm antennas. If you require a galvanic separation (case 2) for your 60 cm or 90 cm EPAK antenna, please indicate this in your order.

In order to avoid galvanic corrosion, the hull of a ship is sometimes electrically decoupled from the rest of the electronics. The hull of a ship is therefore at a very unique potential. In this case, this potential must not be connected within the antenna system.

Case 1: same potential

An electrical connection should be established between terminal/terminal plate, the base plate and the antenna chassis.

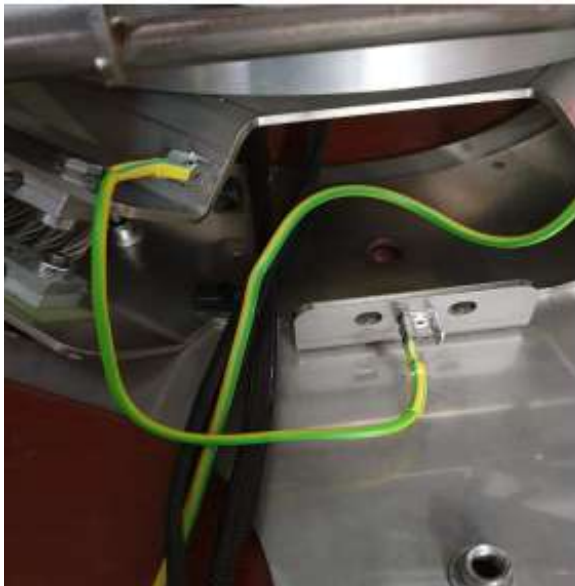

Case 2: different potential

An electrical connection between the terminal/terminal plate and the antenna chassis should be established. The base plate is pulled to the potential of the hull of the ship via the screw connections to the podium/mast/hull. The base plate remains electrically isolated from the rest of the antenna.



4.11 System Cable Connections

Please note the following points before making the connections.

- Ensure to power off the circuit that you are working on to avoid a short.
- Drip-loops should precede the entry point as shown in the below diagram. This will prevent any water from seeping into the ACU.
- The ACU has to be connected to 230 VAC 50 Hz from an online-type UPS otherwise, the warranty on EPAK system will be void.
- After the ODU and IDU are installed, proceed to connect the ACU and ODU as follows:

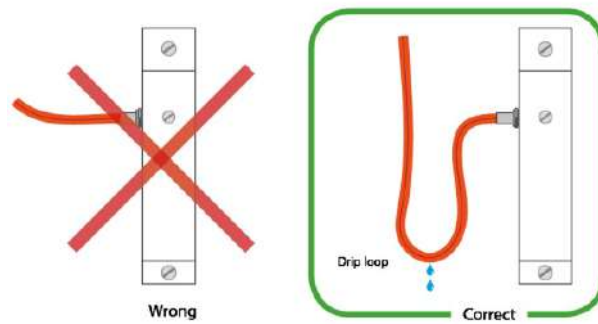

Figure 4.10: Cable connection with a drip loop

- The Antenna Receive (RX) cable (RX+power) must be connected to the ACU.
- All 4 bands from the Antenna (VL, HL, VH, HH) must be connected to the input of multi-switch
- The TV receivers should be connected to the output of the multi-switch.
- The ACU must be connected to 230 V/50 Hz AC from our recommended UPS.
- The vessel network or switch can be connected to Lan1/Lan2 of ACU.
- You can also connect the ship's gyro information (optional) via the NMEA connector at the backpanel of the ACU.

4.12 Wiring TVRO Ku-Band Systems

Cable type:

- ▣ RG6 - doubleshielded satellite coaxial cable (75 Ω) with F-plug at both ends for up to 25m (or 60m with inline amplifier between ACU and Multiswitch)
 OR
 RG 11 - doubleshielded satellite coaxial cable (75 Ω) with F-plug at both ends for up to 40m (or 80m with inline amplifier between ACU and Multiswitch)
- ▣ RG6 coaxial cable 3-way shielded with solid copper core, F-Plugs
- Coax cable with (<18dB@2GHz cable attenuation for best performance) with 1x SMA and 1x N-Plug
 - up to max 20 m: RG58 LSNH double shielded coax cable, 50 Ω
 - up to max 40 m: LMR240, Low-Loss coax cable with a copper core, 50 Ω
- CAT5e/ Ethernet patch cable
- RS422/RS232 (2 Pole)
- Power cord (included)

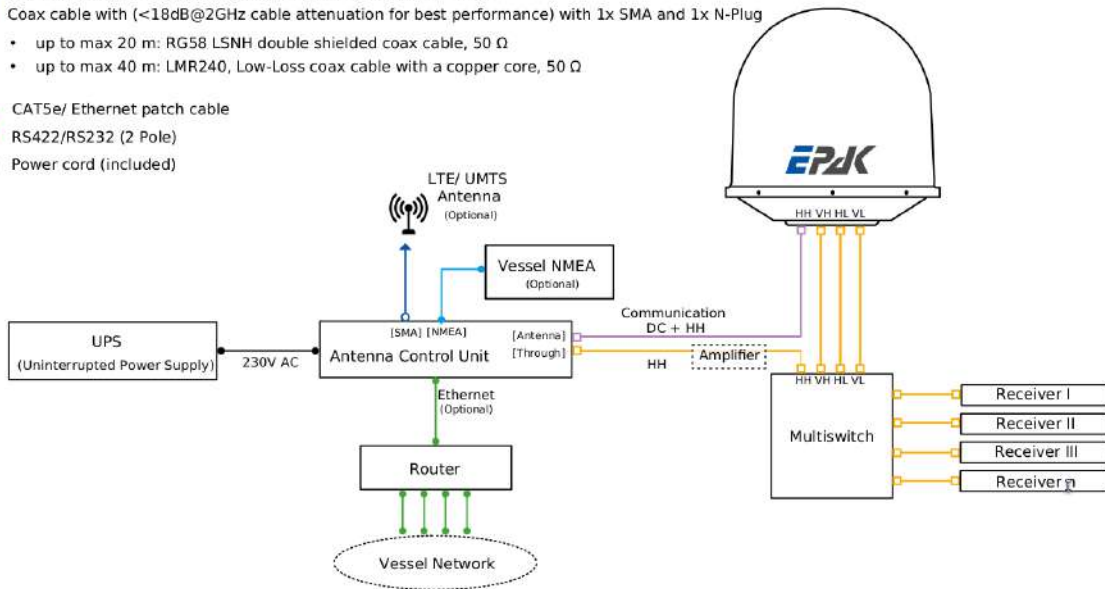

Figure 4.11: Wiring scheme TVRO Ku-Band Systems (4-cable)

5 Operating the TVRO system

Once the Antenna and ACU have been installed safely and all the system cabling is connected, you can power on the system. Please refer to the power supply requirements of this document to check the requirements. If there is already a pre-configured satellite, after powering on the antenna will automatically adjust all its parameters (sensor, gyro, elevation, skew etc.) and lock onto the satellite automatically. However, you can also easily configure the desired parameters from the ACU's web interface.

The ACU has to be mounted into a standard 19-inch rack. All EPAK TVRO systems provide a web interface for basic monitoring and configuration, which can be accessed by connecting to any one of its LAN interfaces. Therefore, it is recommended to mount the ACU where the antenna status can be checked.

The ACU is connected to the ODU via a RG11 or RG6 coaxial cable. This RX cable carries the receive signal in IF and the DC power supply for the antenna. The antenna can receive all 4 bands –VL, HL, VH, HH (Vertical Low, Horizontal Low, Vertical High, Horizontal High). These 4 bands from the Antenna are connected to a multi-switch. The receivers connected to the multi-switch are then able to switch between these bands and surf the TV channels.

You can also connect the ship's compass to the NMEA interface of the ACU for accurate heading information. This heading information is optional, so if it is not connected, the antenna relies on the heading data obtained from the GPS receiver fixed to the antenna.

The ACU is also additionally equipped with an LTE modem. To use the LTE, connect a compatible LTE / UMTS antenna with an SMA cable. Please check the description given below for a short overview of the key functions of the ACU.

5.1 ACU panel

The EPAK TVRO system is operated by the control unit. See below for a short overview of its front and back panel and its corresponding functionality.

Front-panel keys:



Figure 5.1: ACU Front view

| | |
|--------------------|---|
| A: Power Switch | E: Status LEDs (RX- Lock status, Net- Internet Access, NET- Errors) |
| B: Service Port | F: Display |
| C: USB port | G: Input buttons |
| D: LAN1 connection | H: SIM card slots- SIM1, SIM2 |

| | | |
|---|---------------|---|
| A | Power Switch | Switch the ACU on or off. Hold this button for 2s to force the ACU to shut down. |
| B | Service Hatch | The Service hatch covers a micro-USB port and an RF port (to check the received signal spectrum). Only to be removed by service technicians or if you are instructed by a technician to do so. |
| C | USB Port | This port is used to mount a USB drive. |
| D | LAN1 Port | This port can be connected to your local network, a network switch, or a PC |
| E | Status LEDs | Shows a quick view of the status of the Receive Signal, Internet connectivity, and System errors status. RX – (green – Antenna locked, blue – unlocked, off / white – No connection to antenna) NET – (green – Internet Access to ACU via LTE or any other external gateway, blue – no access to Internet) Status – (red – Errors in ACU, off / white – no ACU errors) |
| F | Display | Displays the current status of the ACU and antenna. |
| G | Input Buttons | The input keys lets you navigate the menu and access quick settings. |
| H | SIM Slots | Insert standard SIM cards in SIM1 or SIM2 |

Back-Panel Schematic:

Front-panel keys:

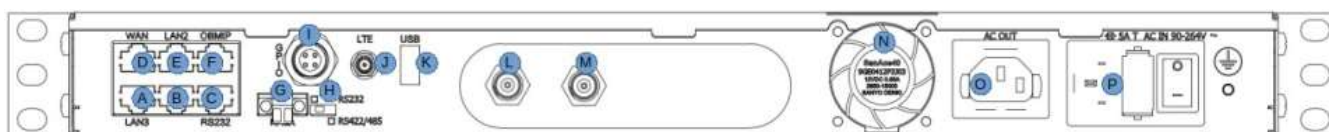

Figure 5.2: ACU Rear view

| | | |
|---------------------------|--------------------------|---------------------------------|
| A: LAN3 Connector | G: NMEA Connector | M: Multi-switch (HH) |
| B: unused port | H: NMEA Protocol Select | N: Fan Outlet |
| C: Serial Connector RS232 | I: GPIO Connector (opt.) | O: Slave Mains Power Connector |
| D: WAN Connector | J: LTE Antenna connector | P: Mains Power Input and Switch |
| E: LAN2 Connector | K: USB Port | |
| F: OpenBMIP Connector | L: Antenna (HH) | |

| | | |
|---|--|---|
| A | LAN3 Connector (RJ45) | This port can be connected to your local network, a network switch or a PC. |
| B | Unused port | – |
| C | Serial Connector RS232 (RJ45) | Connect this port to an RS232 device which should be controlled by the ACU. Use this port only if you are instructed to do so by a technician. |
| D | WAN Connector (RJ45) | Connect this port to the WAN port of your modem. |
| E | LAN2 Connector (RJ45) | Connect this port to your local network, a network switch, or a PC. |
| F | OpenBMIP Connector (RJ45) | Unused port for TVRO |
| G | NMEA Connector (two poles) | Use this port to connect (if available) the ACU to your vessels' compass. Observe correct polarity. |
| H | NMEA Protocol Select Switch | Set this switch according to the used NMEA protocol on your vessel (RS232 or RS422/RS485). Change only if you are instructed to do so by a technician. |
| I | GPIO Connector | Optional connector to extend the ACUs connectivity by two general purpose inputs or outputs. |
| J | LTE Connector | Connect the LTE antenna to this port. |
| K | USB Port | Use this port to communicate serially with the ACU |
| L | Antenna (HH) | F-Type connector. Carries DC power from ACU to the Antenna |
| M | Multiswitch (HH) | F-Type connector. Carriers Horizontal-High band frequency from antenna |
| N | Fan Outlet | The ACU is a high-power device, make sure that the fan outlet is never obstructed. |
| O | Slave Mains Connector | Connect the power supply of your modem to this port. |
| P | Mains Switch & Mains Input & Fuse Holder | Switches the ACU off completely. Connect the ACU to a 110V or 230V AC outlet. Access this hatch to replace a broken fuse. |

¹ Those connectors carry the supply voltage for the antenna. Do not connect or disconnect while the ACU is turned on!

Access to the Webinterface:



Figure 5.3: ACU rear view Access to Web-interface

Connect a computer to this port if you need to access the ACU via the network.

Access: LAN1/ LAN2 with Ethernet cable
 Address: 192.168.10.254 / 192.168.20.254
 Username: admin
 Password: <last 5 digits of ACU serial number>

Please contact itservice@epak.de for remote support.

5.2 Accessing the ACU

All EPAK TVRO systems provide a web interface for basic monitoring and configuration. The connection interface is provided by any PC connected to the ACU (through a local network connection). Users can simply use their web browser to access this functionality without additional software installation.

| | LAN1 | LAN2 |
|----------------|---------------------------------|---------------------------------|
| ACU IP address | 192.168.10.254 | 192.168.20.254 |
| Subnet Mask | 255.255.255.0 | 255.255.255.0 |
| DHCP range | 192.168.10.100 – 192.168.10.200 | 192.168.20.100 – 192.168.20.200 |

Enter the supplied username and password to gain access to the features. If you do not have the login details, please contact your administrator or EPAK IT service. In case your system has not been configured yet, use the following credentials:

Username: admin

Password: <last 5 digits of ACU serial number>



Navigation Menu

Upon successful login, the user overview page will be displayed on the screen. On the left-hand side of the screen, you can see the Navigation menu. This menu shows the sections where you can view the ACU status and change various configurations of the system. Selecting the *Overview* link will bring you back to the Home (*Overview*) page.

System Status

In this section, you can view various system states and monitor the health of the system. This page shows the live status of the ACU and antenna. You can access the Navigation Menu and the Display customization menu on the left-hand side of this screen.

5.2.1 Status -> Dashboard

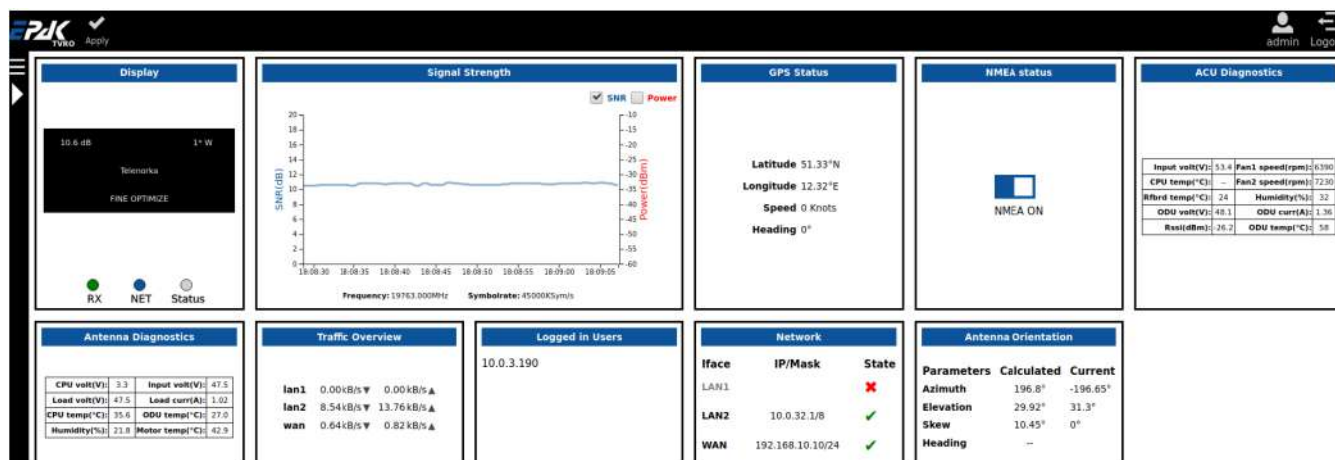

Display:

View live details about the received signal, like the received SNR in dB, the orbit position of the satellite, the satellite name, and the current state of the antenna (Power on / Searching / Optimize / Fine Optimize).



Status LEDs:

There are 3 LEDs on the ACU front-panel. The first RX LED **represents** the Receive Status of the Antenna (Green - RX lock, Blue - No RX lock, white/off - No connection to antenna). The second LED represents the Network status in the ACU (green - internet connection either via LTE or external gateway, blue - no internet connection). The last LED shows the system errors (Red - error in ACU, white /off - no errors).

Signal Strength:

View the live Signal to Noise ratio (dB), signal power (dBm), and the frequency and symbol rate of the received signal.

GPS Position:

This widget shows the GPS position, vessel speed and the heading according to the GPS antenna mounted on the ODU.

ACU Diagnostics:

The ACU diagnostics report shows the live report of following ACU parameters: input voltage measured from the PSU line (Input Volt), speed in rpm of backside fan (**fan1 speed**), temperature of 12V converter (**T12 Temp**), speed in rpm of board fan (**fan2 speed**), the Central Processing Unit temperature in centigrade (**CPU Temp**), 12V converter current in Ampere (**I12 current**), air temperature inside ACU in centigrade (**Rfbrd temp**), relative percentage humidity inside ACU (**Humidity**).

Antenna Diagnostics:

The Antenna Diagnostics widget show the live report of the following Antenna parameters: The ODU voltage in Volts (**ODU Volt**), the current consumption of the antenna (**ODU curr**), the received signal strength in dbm (**Rssi**), and the temperature measured at the ODU regulator (**ODU temp**).

Traffic Overview:

This widget shows the network bandwidth of each interface of the ACU.

Antenna Orientation:

This widget shows the expected (Calculated) and current Azimuth, Elevation, Skew, and Heading of the antenna.

Logged-in Users:

This widget shows the IP addresses of all the users currently logged in to the system.

Network:

Here you can check the IP addresses of all the network interfaces.

NMEA status

Option to enable/disable transmission of NMEA data from the vessel to the antenna.

It is possible to customize the overview page. To proceed, click on the arrow icon as shown on the right. You can simply show/hide each widget by clicking on the links. After making changes, please click on "Apply" at the top of the page to save your custom view.

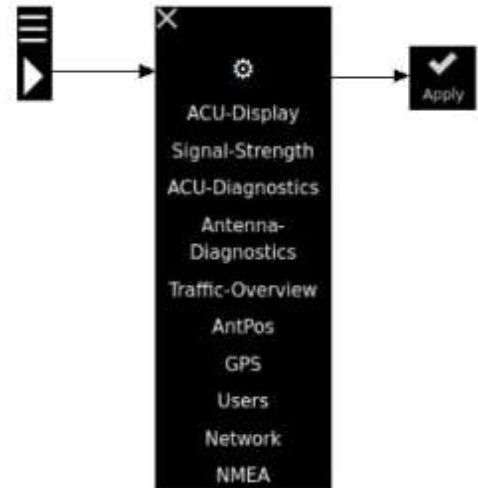

5.2.2 Status -> Network

The Network Page shows the network traffic on each network interface on an hourly and monthly basis. You can also check the live network traffic on the dynamic graphs on the right-hand side of the screen.



5.2.3 Status -> System

This page is useful to monitor the functionality of the system. It shows the graphs of CPU load, the memory statistics, the system temperature, and the used disk space. The graphs show data over a day, over the last week, and over the last month.

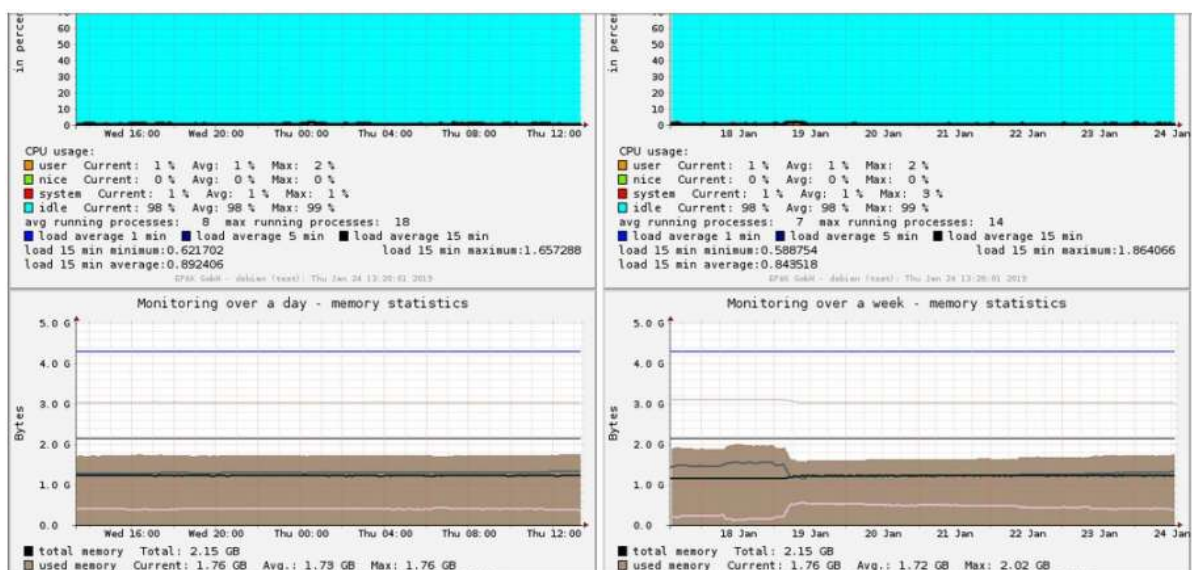

5.3 System Configuration

This section is used to configure the ACU network interfaces, add the modem configuration, configure the network priority settings, add the satellite information, control the Antenna's mode of operation, and control and update the ACU software.

Interfaces

In the *Interfaces* section, you can configure the IP addresses of each LAN interface, enter an external gateway IP, enable DHCP on each interface and also select 2 DNS servers for your system.



Firewall

To view the current firewall configuration, please click on "*Firewall*" on the left hand side of the page. Here you can see the firewall rules, policy, zones and interfaces. Currently these rules can only be viewed and not edited.

Network → Firewall

Control Buttons

Clear Restart Update

NET allow

Zones

| Zone | Type |
|------|----------|
| fw | firewall |
| vpn | ipv4 |
| lte | ipv4 |
| loc1 | ipv4 |
| loc2 | ipv4 |
| net | ipv4 |
| ant | ipv4 |

Interfaces

| Zone | Interface |
|------|-----------|
| loc1 | lan1 |
| loc2 | lan2 |
| net | wan |
| ant | wlan0 |
| vpn | tun0 |
| lte | ppp0 |

Policy

| Source | Destination | Policy | Log Level |
|--------|-------------|--------|-----------|
| lte | all | DROP | info |
| vpn | fw | ACCEPT | - |
| fw | lte | ACCEPT | - |
| fw | vpn | ACCEPT | - |
| fw | ant | ACCEPT | - |
| fw | net | ACCEPT | - |
| ant | fw | ACCEPT | - |
| net | fw | ACCEPT | - |
| loc2 | lte | ACCEPT | - |
| loc2 | fw | ACCEPT | - |
| loc2 | net | ACCEPT | - |
| loc1 | lte | ACCEPT | - |
| loc1 | fw | ACCEPT | - |
| loc1 | net | ACCEPT | - |
| all | all | REJECT | info |

Rules

| Rule | Src | Dest | Protocol | Port |
|---------------|-----|------|----------|-------|
| Invalid(DROP) | net | all | - | - |
| ACCEPT | net | fw | tcp | 5001 |
| REJECT | all | fw | tcp | 29281 |
| REJECT | all | fw | tcp | 29282 |
| REJECT | all | fw | tcp | 29283 |
| REJECT | all | fw | tcp | 29284 |
| REJECT | all | fw | tcp | 29285 |
| REJECT | all | fw | tcp | 29286 |
| REJECT | all | fw | tcp | 29287 |

SNAT

| Action | Src | Dest |
|------------|------------------|------|
| MASQUERADE | 10.0.0.0/8 | wan |
| MASQUERADE | 192.168.100.0/24 | wan |
| MASQUERADE | 10.0.0.0/8 | ppp0 |
| MASQUERADE | 192.168.100.0/24 | ppp0 |

Routing

To view the current network routing, click on "Routing" in this section. Normally the LTE or the configured external gateway is used as a default gateway.

Gateway

You can optionally add a external gateway to route a internet connection via the ACU. You can add the IP address type (DHCP / Static). Select the DHCP option if your default gateway has DHCP server enabled. Otherwise enter the gateways IP address, ACU IP address (should be in range of the gateway), the Netmask and VLAN id if valid.

If the gateway is powered by the ACU Power outlet, then you can power off / on or reset it. You can also see if the gateway is reachable or not.

Network → Routing

| Destination | Gateway | Mask | Interface |
|-------------|------------|------|-----------|
| default | 10.10.10.1 | 0 | wan.225 |
| 10.0.0.0 | 0.0.0.0 | 8 | lan1 |
| 10.10.10.0 | 0.0.0.0 | 24 | wan.225 |

External → Gateway

WAN

IP Address type: DHCP static

IP Address Gateway: 192.168.10.1

IP Address ACU: 192.168.10.10

Netmask: 255.255.255.0

VLAN enabled:

Gateway Power Control

ON OFF Reset

CW reachable: yes

5.3.1 Configuration -> Priority

Under *Network → Priority* section you can configure the priorities for all the available networks and enable or disable a particular network. As seen in this screenshot, the LTE has the highest priority, followed by External gateway (wan), External gateway2 and External gateway1. If the higher priority network is "unreachable", then the software will choose to route the next highest priority network (External Gateway (wan)). The current ranking of the networks can be edited by the buttons shown in the table.

Choose to enable or disable a network according to its relevance. If a network is "disabled", it will not be considered during failover procedure. Please also note that the ACU does not do load-balancing between networks. So, a "enabled" network means that this network will be used as a fallback for the currently active one. The preference for any given network is based solely on your choice and does not depend on the speed for any given network. The currently active network is shown at the bottom of this table.

| BASIC | | | |
|-------------------------------------|-----------------------------|---------------|-------------|
| Enable | Network Priority | Edit Priority | Status |
| <input checked="" type="checkbox"/> | LTE [Highest] | ↑ ↓ | Unreachable |
| <input checked="" type="checkbox"/> | Ext. Gateway (wan) | ↑ ↓ | Unreachable |
| <input checked="" type="checkbox"/> | Ext. Gateway1 (lan1) | ↑ ↓ | Unreachable |
| <input type="checkbox"/> | Ext. Gateway2 (lan2) | ↑ ↓ | Unreachable |

Active Connection: none

The network configuration for Ext. Gateway (WAN) can be found under *Network* → *Gateway*. The external gateway settings (LAN1 and LAN2) can be configured under the *Network* → *Interfaces* section. Enter the gateway IP address for these interfaces in this section.

For configuring the LTE, please switch to *Network* → *LTE* section. The ACU has 2 SIM slots available, only one can be activated at a time. Please select the correct SIM slot by clicking on SIM1 or SIM2.

Select SIM slot

SIM1 SIM2

Dialer Information

PIN:

Network Provider:

APN addr:

Username:

Password:

SIM status: SIM not inserted

Connection Status

| Network | Availability |
|----------------------|--------------|
| LTE | unreachable |
| Ext. Gateway (WAN) | unreachable |
| Ext. Gateway1 (LAN1) | unreachable |
| Ext. Gateway2 (LAN2) | unreachable |

Active Connection: none

LTE Data Usage Settings

Monthly Used: 0 KB

Data Usage Limit:

Monthly Allowance: KB

Start Date:

Status: Disconnected

Signal Quality: No carrier

Blacklist countries

Greece
Netherlands
Belgium
France

LTE Roaming

In the Dialer Information box, enter your SIM PIN if it needs to be unlocked. Select the Network Provider settings - auto / manual. Some SIMs require different APN, Username and password settings. Please check if the current settings match yours. To make any changes to the dialer information, please choose "manual" for the Network Provider and Save the changes. Once the Dialer Information is complete, the LTE will be connected automatically.

Configure and view the LTE data usage settings under *LTE Data Usage Settings* widget. The monthly used data can be reset or you can limit the current usage by turning on the "Data Usage Limit" option. The Monthly allowance value and unit (in KB or MB or GB) can be set and the start date for a new monthly cycle can be entered. Please click on "Save" to add your changes. So if the Data Usage limit is on and if the Monthly used exceeds the monthly allowance, the LTE will be automatically disconnected.

Additionally, you can enter countries in "blacklist" in order to block the LTE usage in them. The currently "blacklisted" countries can be seen under the "current list". You can also enable or disable roaming for LTE on this page.

5.3.2 Configuration -> Antenna

In this section, you can select the antenna's control on this page. If the antenna is required to automatically track the satellite, then switch to **"Change Control: auto"**. If you require the antenna to be pointed manually (with automatic tracking off) then select **"Change Control: manual"**. Then it is possible to control the antenna's elevation, azimuth, and skew from the widget **"Manual Control"**. The minimum possible movement in any direction is 0.01°. The antenna's position can be monitored from the **"Antenna Parameters"** widget.

To select a new beam, click on one of the beams under **"Change Beam"** widget on this page and the antenna will automatically repoint to this new beam.

Adjust the tilt for the satellite in the **"Adjust Tilt"** widget. This feature is only used for testing purposes and it is not required to do this for every satellite.

The **"Tracking performance"** is to evaluate the antennas tracking features. The results of the evaluation could be seen at the end with the results shown as **"pass"** or **"fail"**.

5.3.3 Configuration -> Satellite

View and configure new satellites in this section. Each widget on the page represents a satellite and its beams. You can edit or delete each entry of this section. To confirm the changes, please click on the check **"✓"** button and to rollback click on cancel **"✗"** button.

You can also add new Satellites in this section.

| | | Thor1 | | | at 0.8° W with a tilt of 0° | |
|-------|-----|----------------|---------------------|-------------------------|--------------------------------|--|
| Beams | ID | RX Polarity | Frequency in MHz | Symbolrate in kSym/s | | |
| ↗ | 381 | V | 12336 | 19000 | | |
| ↘ | 380 | V | 10736 | 19000 | | |

Beam +

| new* | | ... adding ... |
|----------|---|----------------|
| Name | <input type="text"/> | |
| Position | <input type="text"/> in Degree (W<0°<E) | |
| Tilt | <input type="text"/> 0 in Degree | |

Click on the



button on your screen, then enter the satellite name, the position and tilt if any. To save your entry, click on the check **"✓"** button and to undo your changes click on cancel **"✗"** button.

***Note-** If the satellite is in the West orbit, you must enter a negative number in the Position field. eg. 22West will be -22.

To add new beams for a satellite, click on **"Beam+"** button and enter the beam ID, receive polarity, receive RF frequency and symbol rate in ksym/s. The beam ID can be any number between 1 to 9999. To save your entry, click on the check **"✓"** button and to undo your changes click on **"✗"** button.

| | | Thor1 | | | at 0.8° W with a tilt of 0° | |
|-------------|----------------------|----------------|---------------------|-------------------------|--------------------------------|--|
| Beams | ID | RX Polarity | Frequency in MHz | Symbolrate in kSym/s | | |
| ✓ | ✗ | + | ... adding Beam ... | | | |
| ID | <input type="text"/> | (1..9999) | | | | |
| RX Polarity | Vertical | | | | | |
| Frequency | <input type="text"/> | MHz | | | | |
| Symbolrate | <input type="text"/> | kSym/s | | | | |

5.3.4 Configuration -> Versions -> Update Section

This section is used for updating the antenna firmware or updating the ACU Software version. It gives an overview of the ACU software and hardware version, and the antenna information. To update the antenna's firmware or the ACU software, please contact the EPAK IT team.

Update / Import / Export

Update Antenna-Firmware

click here to

 upload a patch-file

Update ACU-Firmware

click here to

 upload a patch-file

Update ACU-Software

connect to server
 →
 and perform update

ACU

SN: **10036**

ACU HW: **v7-3**

ACU SW: **0.7.2-483**

ACU SW-Branch: **master**

ACU FW: **v1.1.0-1**

Antenna

SN: **090UC.12.1921.1000**

CPUID: **31002C000951373235343632**

SW Build: **202009172010**

Type: **DSI9**

Dishsize: **90 cm x 90 cm**

If the system is misbehaving after any update, please consider to reboot the ACU.

Import/Export

In this section, you can choose to "Export" or "Save" the existing Network configuration, the configured satellites or beams. The "Export" button will download the chosen configuration to your PC, and the "Save" button will create a backup on the ACU.

Update / Import / Export

Export / Save

- Network
 - Gateway
 - Interfaces
 - DNS
- Satellites
- Antenna

Restore

| | |
|----------------------|--|
| 2020-08-18T14:32:08Z | |
| 2020-08-19T08:25:58Z | |
| 2020-08-20T14:36:24Z | |
| 2020-08-24T08:42:09Z | |

Import

click here to

 import a configuration

All the current backups are listed under the Restore window. To restore a backup, click on the desired backup file, select the setting, and confirm. To delete the backup file click on the corresponding delete button. Under the "Import" window, you can also import a downloaded configuration file.

5.4 Account Details

To see details about your account, click on the user icon on the top-right side of your screen. You will be redirected to your account details. Here you can view your username, shortname, and status. You can also view your recent login history on this page. If you are the "admin" user, you can view the login history for other users as well.

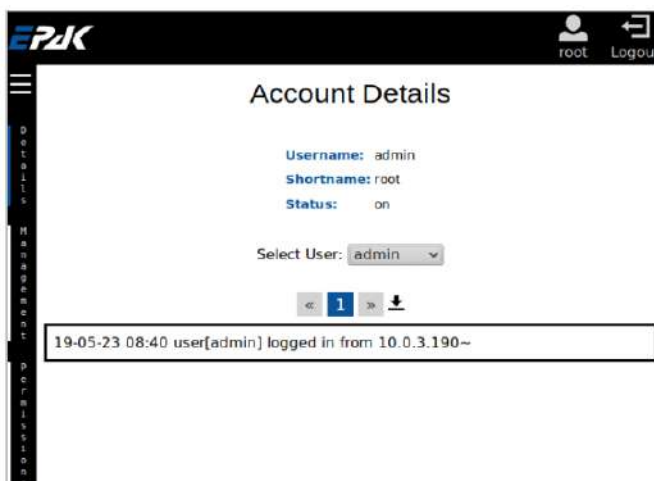

User Management

The user management page is accessible by clicking on the user button on the left side of the screen. In this section, you can view the current login name, short name, and other account creation details. Here you can also change your password and short name. The admin user can add, delete, enable/disable a new user.

User Permissions

The permissions page is limited to use by the admin user. It is accessible by clicking the permissions button on the left side of the screen. The admin user can set the page permissions for each page for every user in this section. To save the changes, click on the "Apply" button at the top of this page.

5.5 Maintenance

The EPAK TVRO system is easy to maintain. The following instructions are sufficient to sustain the optimal performance of the antenna:

Outdoor Unit (antenna)

- Clean the radome once a month using fresh water and a mild detergent to remove dirt and salt deposits.
- Do not operate the antenna without the radome.
- Do not clean the radome with a high-pressure washer or high-pressure water from a hose.
- Check cable connections to be tight and free of corrosion. Clean the cables regularly.

The radome has a protective layer of UV-stabilized and maritime climate-proof coating. Do not apply any wax, preservative, solvent, chemicals, or adhesive labels. Do not use alcohol or dilution or similar products to clean the radome. In case any solvent comes in contact with the radome by accident, rinse the area immediately with water and, if necessary, with a mild detergent. A guarantee for UV and colour stability as well as fracture strength can only be given within the warranty of the supplier/dealer.

Indoor Unit (ACU)

- Clean the filter on the front of the ACU if it is visible dusty. (Vacuum from the front, do not open the casing).

5.6 Individual dome painting

Customers may wish to paint the domes in order to match the vessel's colour. The paint and primer must be free of any metallic components (like zinc). Any painting may impact the RF performance. The thickness of the paint affects the attenuation of the signal. The thinner the paint is applied the better. Ideally, the dome should not be painted at all.

6 Hardware configuration

The EPAK antenna can be paired with various types of hardware to accommodate your requirements for internet speed and connectivity. Please check this section for more information on the types LNBS used.

6.1 LNBS

EPAK systems are compatible with all universal LNB with LOF at 9.75 / 10.6 GHz.

6.2 NMEA Connector

Optionally you can connect the vessel's gyro compass to the NMEA port at the back-panel of the ACU. Please check for the correct polarity. Kindly refer to Figure 5.2 "ACU rear view" in this document for more details. You can also select the NMEA protocol (RS232 or RS444/RS485) depending on what is available.

7 Datasheets

Please find the technical specifications of the ACU and antenna in this section.

| Antenna Control Unit | |
|---------------------------------|--|
| Dimensions | 48 cm × 4.45 cm × 47.8 cm (18.9" × 1.75" × 18.82") (19" Rack 1HU size) |
| Weight | 5.1kg (11.24lbs) |
| Gyro Interface | NMEA0183 / NMEA 2000 (via RS422 or RS485 or RS232) / SIMRAD RGC11 |
| Input voltage, frequency | 90 ~ 264V AC, 47~63Hz |
| External I/O | RS232, RS422, Ethernet, USB, GPIO |
| Local user Interface | OLED display, directional pad, 2 push keys |
| Remote access | TCP / IP |
| Operating temperature | -20°C to 55°C |
| Storage temperature | -40°C to 85°C |
| Humidity | According to IEC 60945 |
| IP class | IP 30 |
| Compass safe distance | 0.5m according to IEC 60945 |
| Position acquisition | supplied by ODU |
| Cables & Connections | |
| ACU to Antenna | 2x Double shielded coax cable (ECOFLEX 10) with N-plugs |
| ACU to Network | Ethernet patch with RJ45 plugs |
| ACU to Multiswitch | 4x double shielded RG6/ RG11 satellite coaxial cable (75Ω) with F–plug at both ends |
| ACU to LTE | Coax cable with <18dB cable attenuation for best performance, with 1x SMA- and 1xN-Plug <ul style="list-style-type: none"> • up to max 20 m: RG58 LSNH double shielded coax cable, 50Ω • up to max 40 m: LMR240, Low-Loss coax cable with copper core, 50Ω |

7.1 Antenna

DS6 PRO
DS9 PRO
DS13 PRO

Please refer to the datasheets, available on our website. <https://www.epak.de/en/support/download-area>

8 Glossary

| | |
|-----------|---|
| ACU | Antenna Control Unit. Used to control the antenna and provide the vessel with internet access. |
| Azimuth | The horizontal angle a parabolic antenna must be rotated to, in order to point to a specific satellite in the orbit. It is defined with respect to the north for convenience. |
| Elevation | The vertical angle that a parabolic antenna has to set to point to a specific satellite in orbit. Elevation is zero when the antenna points to the horizon. |
| GPS | Global Positioning System |
| IDU | Indoor Unit |
| Ku-Band | The frequency range from 10.7 to 18GHz. |
| LNB | A Low Noise Block is used for the reception (downlink) of satellite signals. It downconverts a block of high-range frequencies to a lower range. So LNBs convert Ku Band frequencies to L Band. |
| NMEA | Communication standard for marine instruments |
| ODU | Outdoor Unit (Antenna) |
| Skew | Skew is the tilt of the LNB in order to align the planes of polarization of the antenna & the satellite. |
| UPS | Uninterrupted Power Supply. Online type is recommended for EPAK systems. |
| SNR | The ratio of signal power to noise power, expressed in dB. The higher the SNR, the better the signal quality. |
| TVRO | Maritime TV receive Only System antenna |

Drilling Pattern DSi6

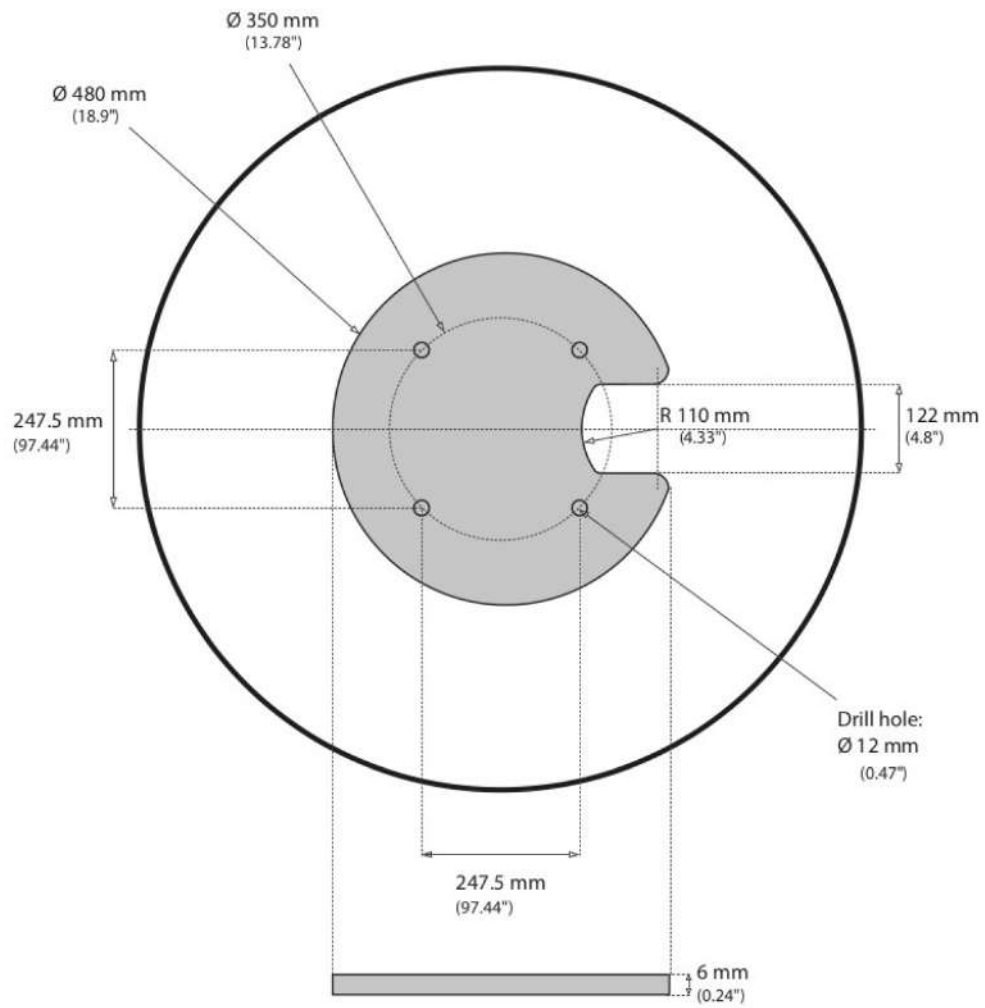

Figure 8.1: Drilling Pattern 60cm TVRO

Drilling Pattern DS9

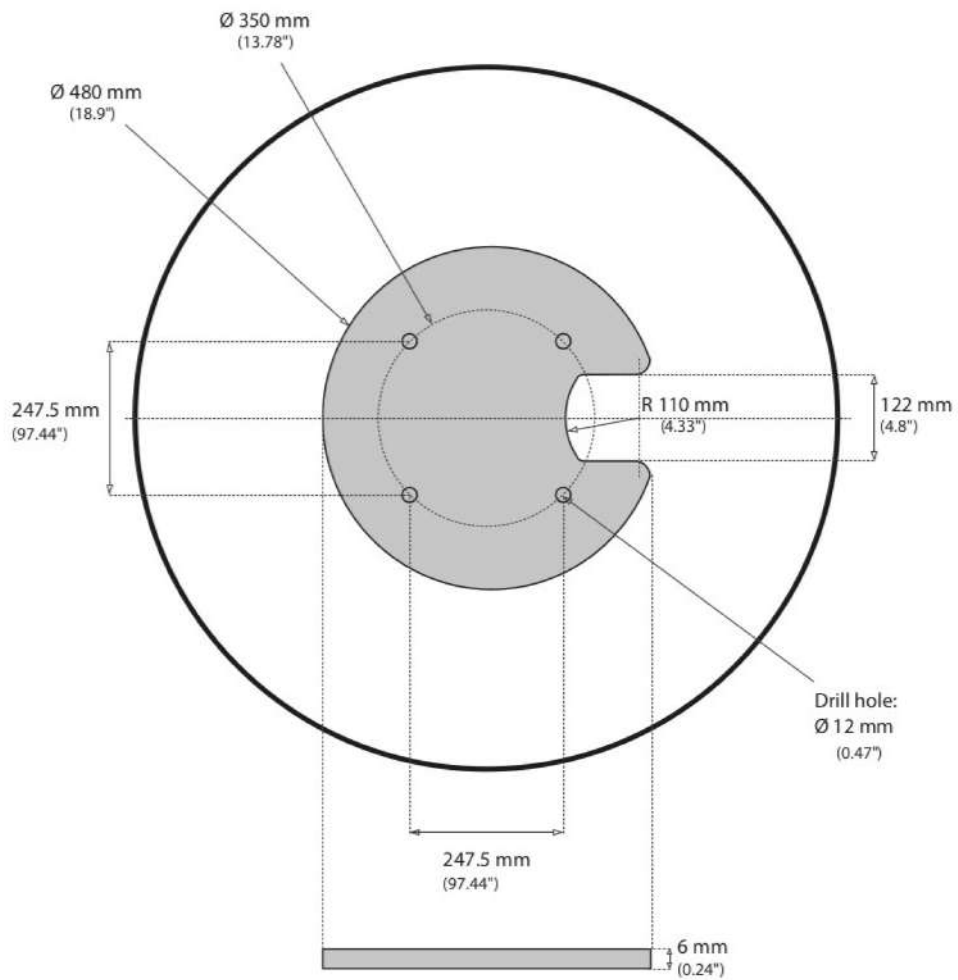

Figure 8.2: Drilling Pattern 90cm TVRO

Drilling Pattern DS13

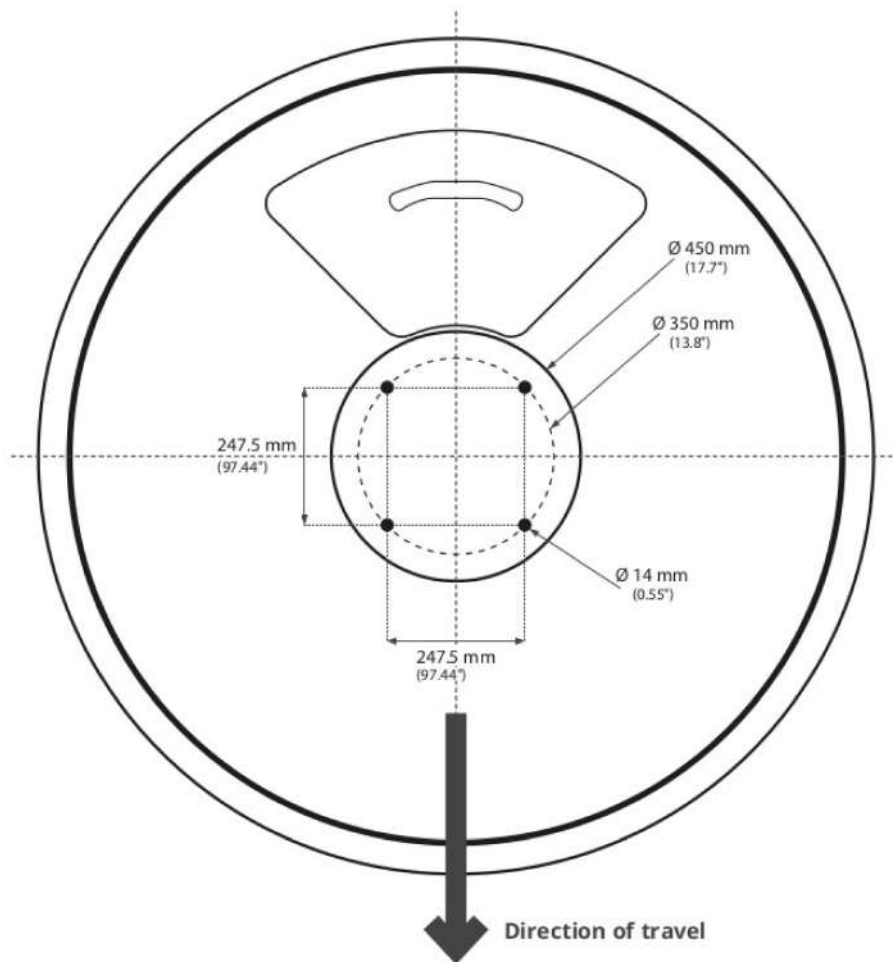

Figure 8.3: Drilling Pattern 130cm TVRO

Picture Index

| | | |
|------|---|----|
| 1 | Antenna label with serial number | 2 |
| 4.1 | Finding the best location for the antenna | 8 |
| 4.2 | Minimum safe distance from the radar | 9 |
| 4.3 | Dimensions 60 cm antenna dome (front and bottom) | 11 |
| 4.4 | Dimensions 90 cm antenna dome (front and bottom) | 11 |
| 4.5 | Dimensions 130 cm antenna dome (front and bottom) | 11 |
| 4.6 | Position of transport locks | 13 |
| 4.7 | Transportation lock open-closed | 14 |
| 4.8 | ACU Front view | 14 |
| 4.9 | ACU Top view | 15 |
| 4.10 | Cable connection with a drip loop | 17 |
| 4.11 | Wiring scheme TVRO Ku-Band Systems (4-cable) | 18 |
| 5.1 | ACU Front view | 19 |
| 5.2 | ACU Rear view | 20 |
| 5.3 | ACU rear view Access to Web-interface | 21 |
| 8.1 | Drilling Pattern 60cm TVRO | 34 |
| 8.2 | Drilling Pattern 90cm TVRO | 35 |
| 8.3 | Drilling Pattern 130cm TVRO | 36 |